

# 100T SHOP PRESS



## Instruction Manual

**Please read this instruction manual carefully before use.**

## Contents

Important information .....	1
1. Safety information .....	1
2. General Information.....	3
3. Parts List of shop press.....	4
4. Parts list of ram .....	6
5. Parts list of pump .....	7
6. Parts list of manual selector valve .....	9
7. Parts list of working bed lifting equipment.....	10
8. Parts list of ram moving equipment .....	11
9. Parts list of heel block .....	11
10. Unpacking.....	13
11. Assembling .....	14
12. Ram moving .....	15
13. Bed adjustment.....	16
14. Handle tube .....	16
15. Air Purge .....	16
16. Piston's extension & retraction .....	17
17. Press setup.....	18
18. Operation.....	19
19. Maintenance .....	20

## Important information

***PLEASE READ THESE INSTRUCTIONS CAREFULLY. NOTE THE SAFETY INSTRUCTIONS AND WARNINGS. USE THE PRODUCT CORRECTLY AND WITH CARE FOR THE PURPOSE FOR WHICH IT IS INTENDED. FAILURE TO DO SO MAY CAUSE DAMAGE TO PROPERTY AND/OR PERSONAL INJURY. PLEASE KEEP THIS INSTRUCTION MANUAL SAFE FOR FUTURE USE.***

# 1. SAFETY INSTRUCTION AND WARNINGS

- 1.1 Use a qualified person to maintain the lift in good condition. Keep it clean for best and safest performance.
- 1.2 The maximum load is 100Ton. **DO NOT** exceed this rated capacity. Never apply excessive force to a workpiece and always use the pressure gauge to accurately determine the applied load. Burst hazard exists if hose or connection pressure exceeds rated pressure.
- 1.3 Shop presses are designed for automotive, truck, implement, fleet, and industrial repair shops where pressing, bending, straightening, forming, holding is required. Each press includes a cylinder, a pump, and lifting bar which provides a safe way to raise and lower the bed frame, and a pressure gauge which provides for monitoring the applied press force.
- 1.4 Keep children and unauthorized persons away from the work area.
- 1.5 Remove ill fitting clothing. Remove ties, watches, rings and other loose jewelry, and contain long hair.
- 1.6 Wear ANSI approved impact safety goggles, full-face impact safety shield and heavy-duty work gloves when operating the press.
- 1.7 Keep proper balance and footing, do not overreach and wear nonskid footwear.
- 1.8 Only use this press on a surface that is stable, level, dry and not slippery, and capable of sustaining the load. Keep the surface clean, tidy and free from unrelated materials and ensure that there is adequate lighting.
- 1.9 Inspect the press before each use. Do not use if bent, broken, cracked, leaking or otherwise damaged, any suspect parts are noted or it has been subjected to a shock load.
- 1.10 Check to ensure that all applicable bolts and nuts are firmly tightened.
- 1.11 Ensure that workpiece is center-loaded and secure
- 1.12 Keep hands and feet away from bed area at all times.
- 1.13 Do not use the shop press to compress spring or any other item that could disengage and cause a potential hazard. Never stand directly in front of loaded press and never leave loaded press unattended.
- 1.14 Do not operate the press when you are tired or under the influence of alcohol, drugs or any intoxicating medication.
- 1.15 Do not allow untrained persons to operate the press.
- 1.16 Do not make any modifications to the press.
- 1.17 Do not use brake fluid or any other improper fluid and avoid mixing different types of oil when adding hydraulic oil. Only good quality hydraulic jack oil can be used.
- 1.18 Do not expose the press to rain or any other kind of bad weather
- 1.19 If the press need repairing and/or there are any parts that need to be replaced, have it repaired by authorized technicians and only use the replacement parts supplied by the manufacturer.

**WARNING:** the warnings, cautions and instructions discussed in this instruction manual cannot cover all possible conditions and situations that may occur. It must be understood by the operator that common sense and caution are factors which cannot be built into this product, but must be supplied by the operator.

## 2. General Information

Rated Capacity.....	100 Ton	Stroke.....	300 mm
Working Range.....	93-933mm	Working Bed Width.....	787mm
Air Inert Fitting.....	1/4" NPT	Air Pressure.....	120-200PSI
Ram Moving Range.....	250mm		

### 3. Parts List of Shop Press

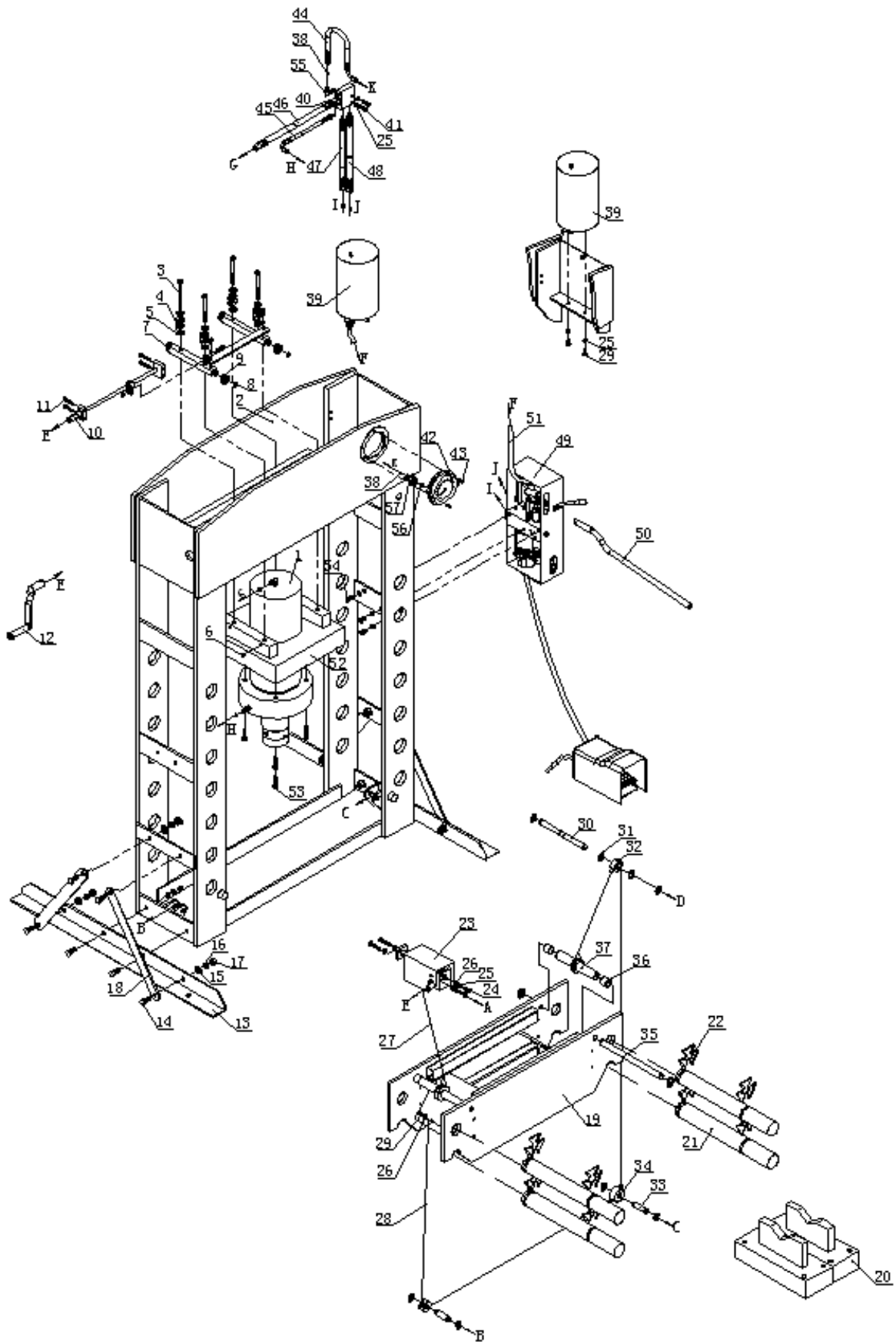

No.	Description	Qty.	No.	Description	Qty.
1	Ram Assy	1	30	Roller Pin	1
2	Body Frame	1	31	Circlip $\phi$ 20	8
3	Hex Bolt M12*130	4	32	Roller With Cover III	1
4	Spring Cove	8	33	Roller Pin 2	2
5	Spring	4	34	Roller With Cover	2
6	Hexagon socket set screw M8*10	4	35	Lifting Bar	2
7	Steel Tube II	2	36	Tube 2	4
8	Circlip $\phi$ 17	4	37	Bushing	1
9	Ball Bearing GB/T276-6203	4	38	O-ring 9*1.9	2
10	Ram Moving Equipment	1	39	Oil Tank	1
11	Hexagon Screw M8*45	4	40	Adapter	1
12	Handle Part	1	41	Hex Screw M10*40	2
13	Base	2	42	Pressure Gauge	1
14	Hex Bolt M12*30	12	43	Screw M5*8	3
15	Washer GB/T95- $\phi$ 12	12	44	Oil Hose 1	1
16	Spring Washer GB/T93- $\phi$ 12	15	45	Oil Hose (Down)	1
17	Hex Nut M12	12	46	Oil Hose 3	1
18	Support	4	47	Oil Hose 1	1
19	Working Bed	1	48	Oil Hose 2	1
20	Heel Block	2	49	Pump Assy	1
21	Pin	4	50	Handle Tube	1
22	Circlip	8	51	Oil Hose	1
23	Working Bed Moving Equipment	1	52	Under Plate	1
24	Hex Screw M10*30	4	53	Hexagon Screw M12*45	4
25	Spring Washer $\phi$ 10	8	54	Hex Bolt M12*25	3
26	Washer $\phi$ 10	5	55	Fitting	1
27	Cable 1.6M	1	56	Nylon Ring	1
28	Cable 4.3M	1	57	Connecting Nut	1
29	Hex Screw M10*20	3			

## 4. Pars List of Ram

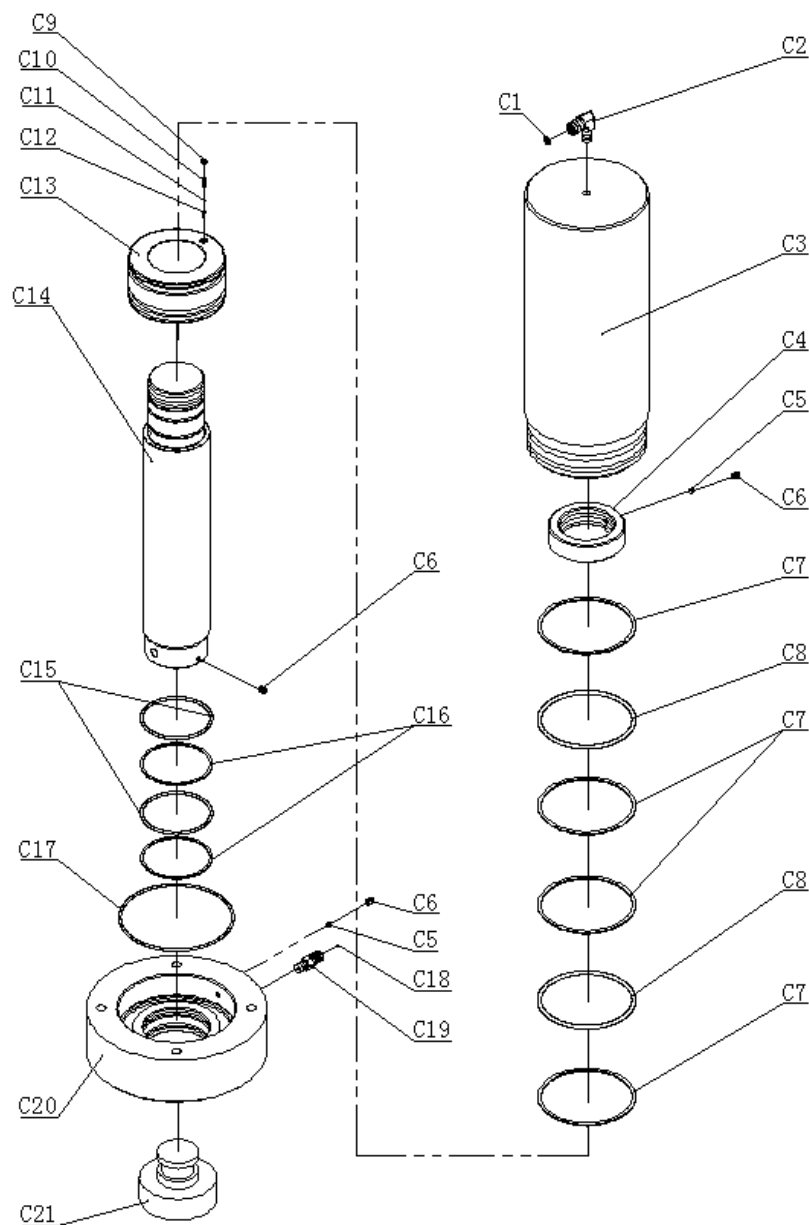

No.	Description	Qty.	No.	Description	Qty.
C1	O-ring 8*2	1	C12	Valve Rod	1
C2	Fitting	1	C13	Piston	1
C3	Cylinder	1	C14	Piston Rod	1
C4	Nut	1	C15	O-ring GB3452.1-96*4	2
C5	Nylon Block	2	C16	PTFE Washer	2
C6	Hexagon Socket Set Screw M8*10	3	C17	O-ring GB3452.1-158.34*3.53	1
C7	PTFE Washer	4	C18	O-ring GB1235-9*1.9	1
C8	O-ring GB3452.1-129.6*5.7	2	C19	Connector I	1
C9	Screw	1	C20	Ring For Ram	1
C10	Spring	1	C21	Serrated Saddle	1
C11	Steel Ball $\phi$ 4.7630				

## 5. Parts List of Pump

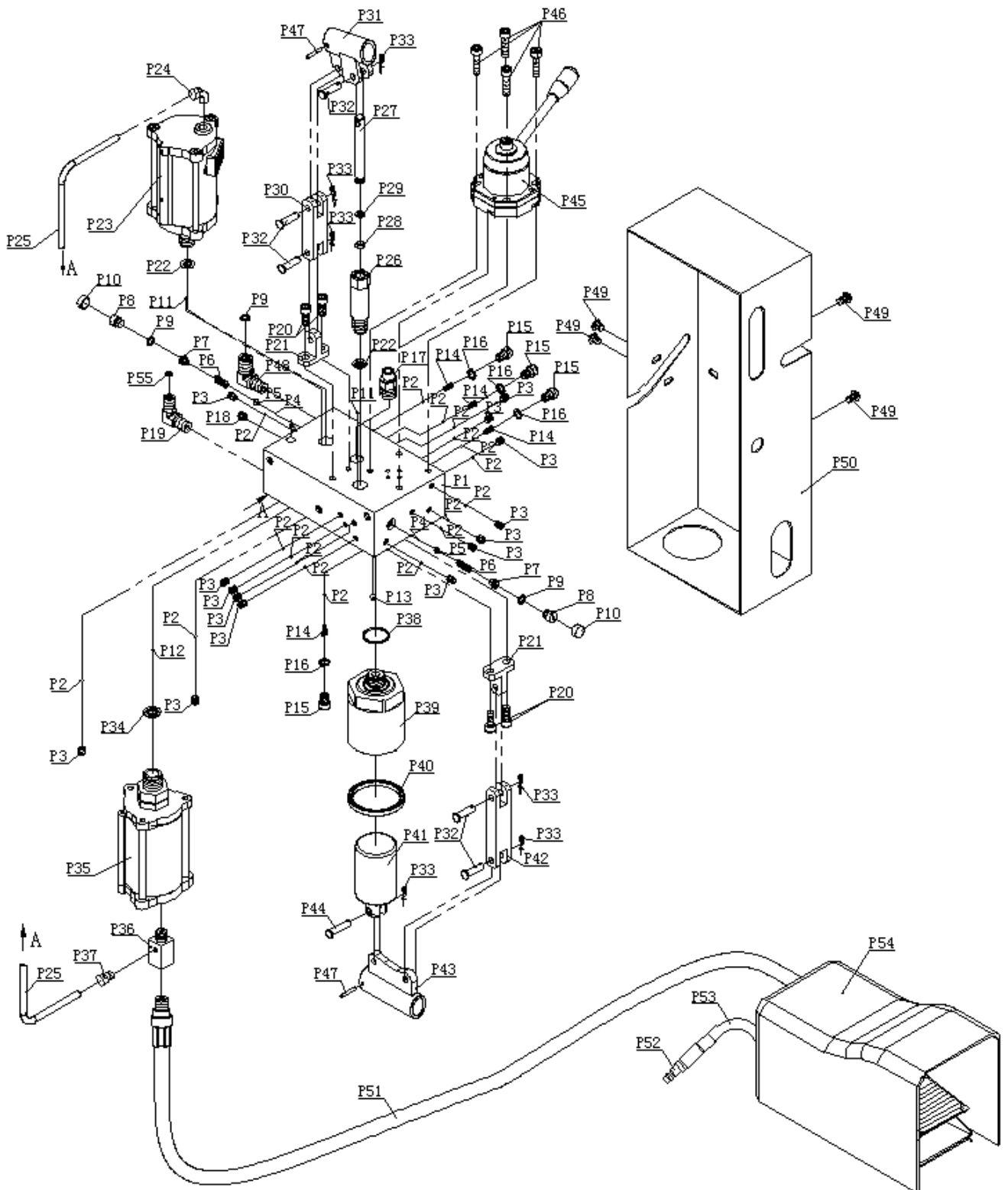

No.	Description	Qty.	No.	Description	Qty.
P1	Pump	1	P29	Circlip	1
P2	Steel Ball $\phi$ 6.0000	18	P30	Connecting Bar	1
P3	Hexagon Socket Set Screw M8*10	14	P31	Handle Socket	1
P4	Steel Ball $\phi$ 3.0000	2	P32	Pin8*30	5
P5	Steel Ball Base	2	P33	R-Pin	6
P6	Spring	2	P34	Copper Washer	1
P7	Screw	2	P35	Air Motor	1
P8	Plug Screw	2	P36	Branch Joint	1
P9	O-ring	2	P37	Connector	1
P10	Cover	2	P38	O-Ring 30*2	1
P11	Steel Ball $\phi$ 5.0000	2	P39	Big Pump Core Base	1
P12	Steel Ball $\phi$ 7.1438	1	P40	U-Ring NOK53*63*6	1
P13	Steel Ball $\phi$ 8.0000	1	P41	Big Pump Core	1
P14	Spring	4	P42	Big Connecting Bar	1
P15	Plug Screw	4	P43	Handle Socket For Low Pressure	1
P16	Copper Washer TT-245	4	P44	Pin 8*35	1
P17	NPT1/2" Connector	1	P45	Manual selector valve	1
P18	NPT1/4" Plug	1	P46	Hexagon Screw M8*35	4
P19	Fitting	1	P47	Spring Pin $\phi$ 4*26	2
P20	Hexagon Bolt M8*20	4	P48	Fitting	1
P21	Connecting Rod Base	2	P49	Flat-head Screw GB70.2-M8*10	4
P22	Copper Washer TT-244	2	P50	Pump Cover	1
P23	Air Motor	1	P51	Air Hose 1	1
P24	NPT1/4"-8 Connector	1	P52	Air Hose Joint	1
P25	PU Tube 8*6	1	P53	Air Hose 2	1
P26	Pump Core Base	1	P54	Air Valve	1
P27	Pump Core	1	P55	O-Ring 9*1.9	1
P28	O-ring 6.5*3	1			

**Pump Features:** The pump assy is composed by four pumps, two for high pressure (one is manual and the other is air) which are located on the top of the pump assy; the other two for low pressure (one is manual and the other is air) which are located in the lower position; and there are one selector valve on the top of the pump assy.

The two pumps for low pressure are used for quick extension of the piston rod without pressure; and the two pumps for high pressure are working when under pressure. The selector valve is used to control the piston rod's returning or extension.



## 6. Parts List of Manual Selector Valve

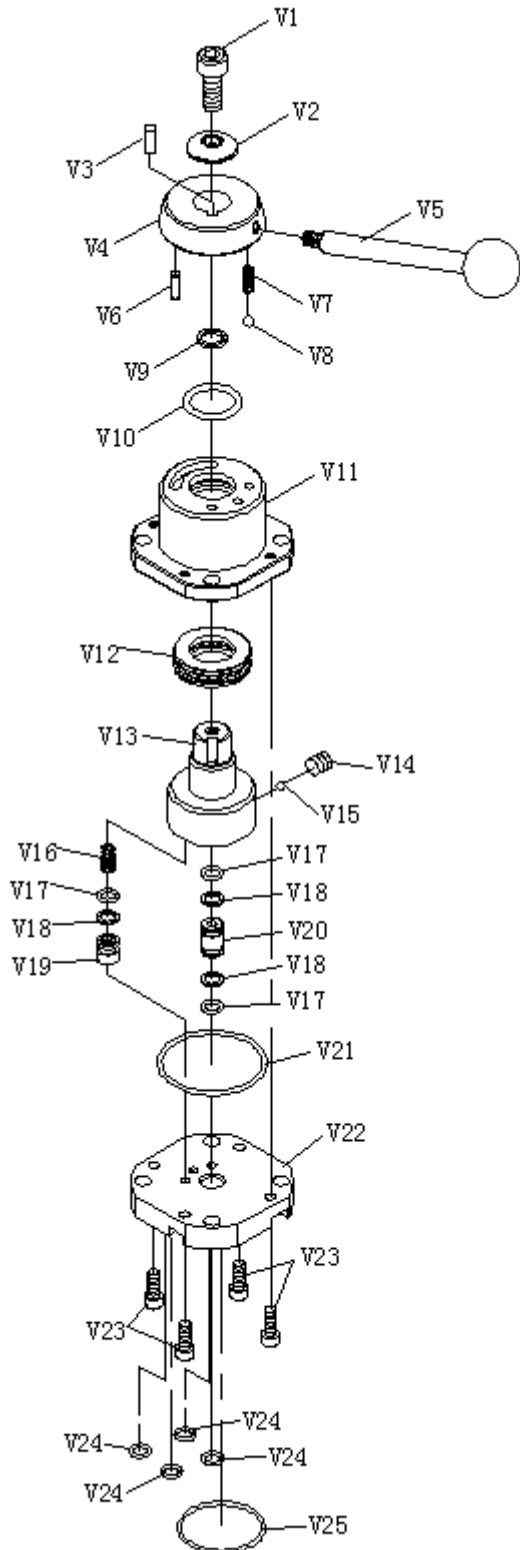

No.	Description	Qty.
V1	Hexagon Screw	1
V2	T Washer	1
V3	Key	1
V4	Moving Cover	1
V5	Handle	1
V6	Pin	1
V7	Spring	1
V8	Steel Ball	1
V9	Copper Washer	1
V10	O-Ring	1
V11	Valve Jacket	1
V12	Ball Bearing	1
V13	Valve Plug	1
V14	Hexagon Socket Set Screw	1
V15	Steel Ball	1
V16	Spring	1
V17	O-Ring	3
V18	PTFE Washer	3
V19	Slide Valve	1
V20	Connector	1
V21	O-Ring	1
V22	Valve Plate	1
V23	Hexagon Screw	4
V24	O-Ring	4
V25	O-Ring	1

## 7. Parts List of Working Bed Lifting Equipment

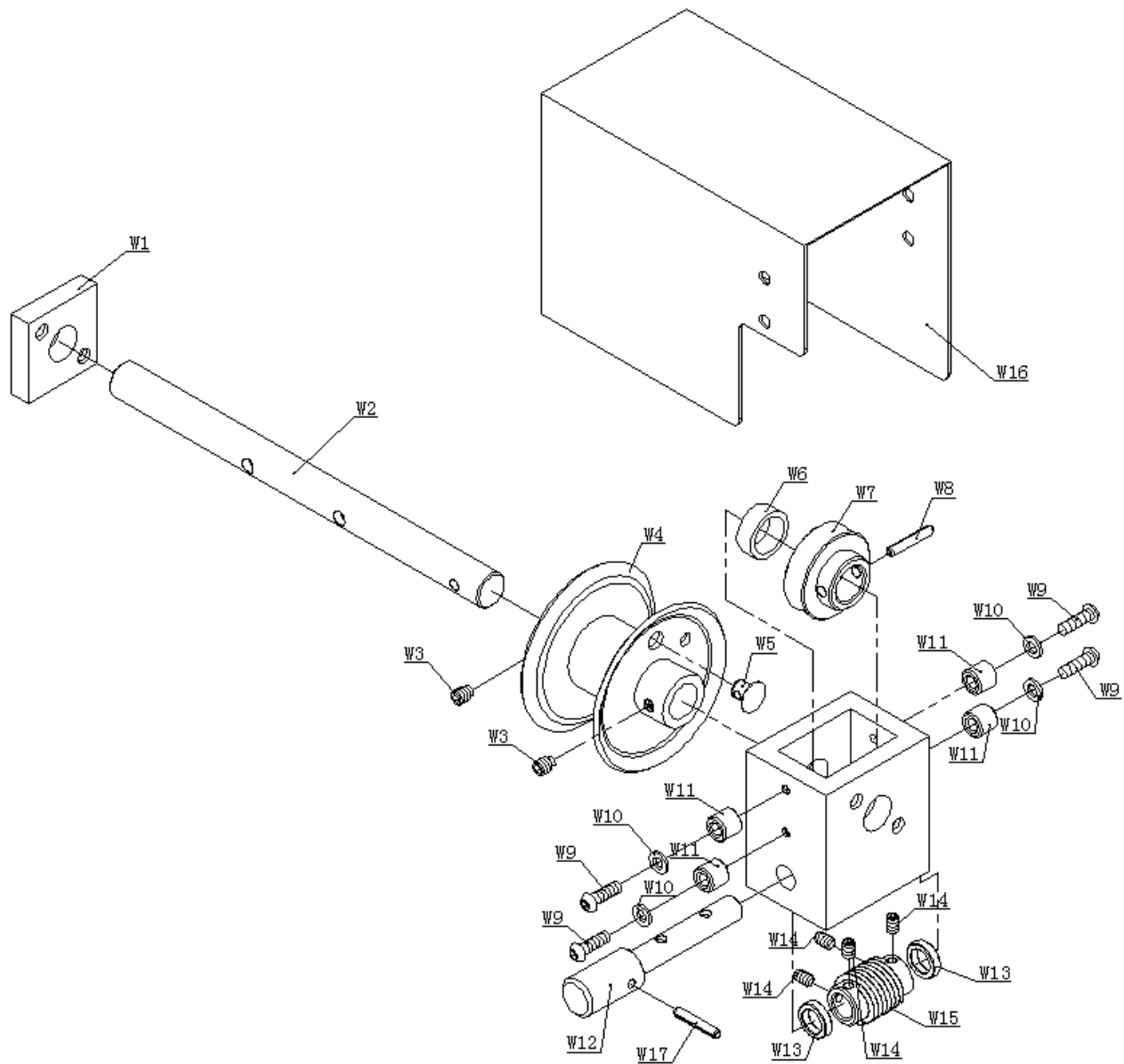

No	Description	Qty.	No	Description	Qty.
W1	Support Plate	1	W10	Washer $\phi$ 10	4
W2	Worm Shaft	1	W11	Washer	4
W3	Hexagon Screw M8*10	2	W12	Worm Shaft	1
W4	Winch	1	W13	Worm Washer	2
W5	Rivet	1	W14	Hexagon Socket Set Screw M6*10	4
W6	Worm Pad	1	W15	Worm	1
W7	Worm	1	W16	Winch Cover	1
W8	Spring Pin $\phi$ 6*30	1	W17	Spring Pin $\phi$ 5*30	1
W9	Hexagon Screw 6*20	4			

## 8. Parts List of Ram Moving Equipment

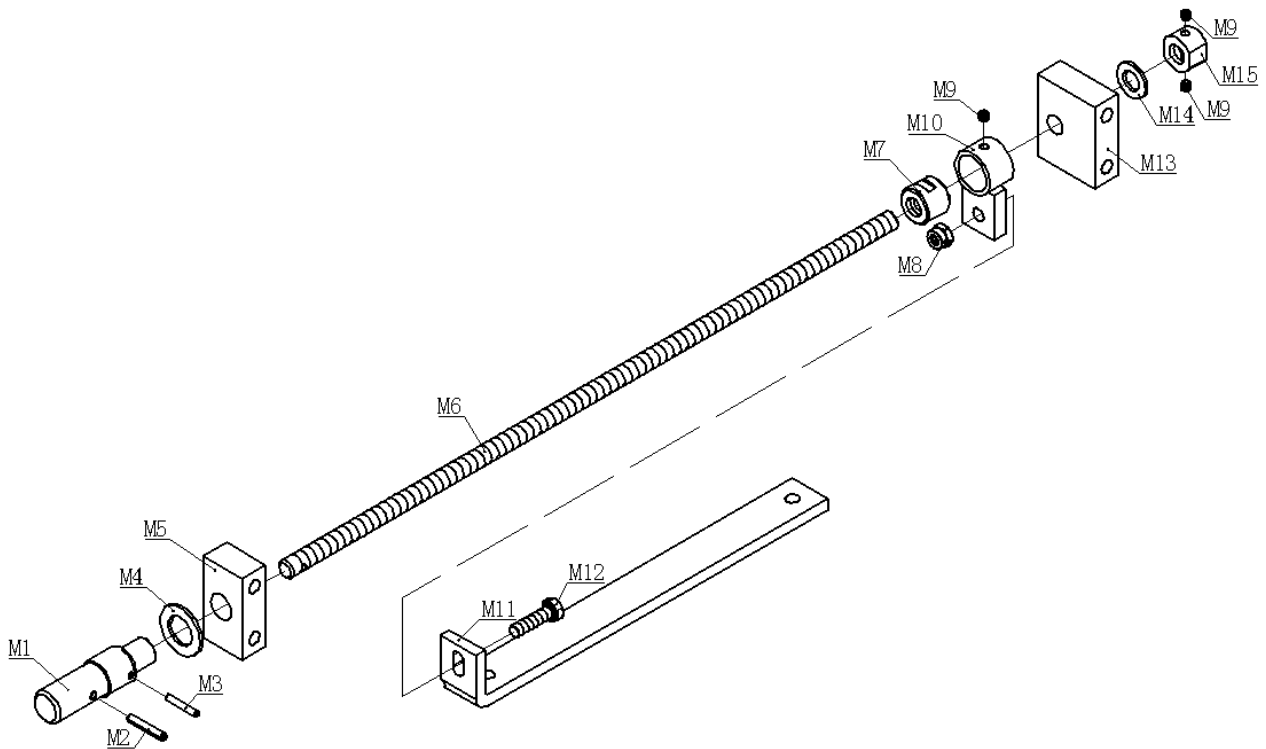

No	Description	Qty.	No	Description	Qty.
M1	Worm Connecting Shaft	1	M9	Hexagon Socket Set Screw M6*5	3
M2	Spring Pin $\phi$ 5*30	1	M10	Nut Cover	1
M3	Spring Pin $\phi$ 4*25	1	M11	Connecting Bar	1
M4	Washer $\phi$ 18	1	M12	Hex Bolt M8*30	1
M5	Support Base 2	1	M13	Screw Base 1	1
M6	Screw	1	M14	Washer $\phi$ 12	1
M7	Nut	1	M15	Locking Nut	1
M8	Damping Nut M8	1			

## 9. Parts List of Heel Blocks

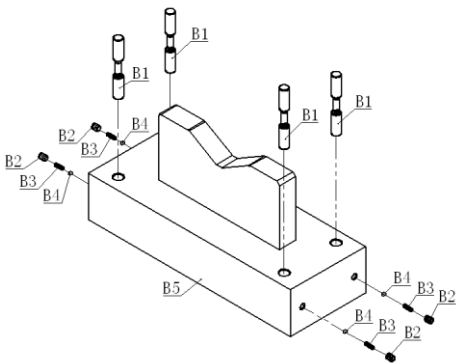

No	Description	Qty.
B1	Limit Screw	4
B2	Hexagon Screw M8*10	4
B3	Spring	4
B4	Steel Ball $\phi$ 4.763	4
B5	Heel Block	1

## 10. Unpacking

1. Unpacking the plywood case.
2. To avoid any damage to the machine or personal injury, remove the small parts packed in case first.
3. Remove the polybag covered the press.
4. Use a fork lift to take the press out of case.
5. Double check parts to ensure they are all there. The parts should include press body frame, pump, base, support, hardware kits, etc. (Detail refer to the following sheet )

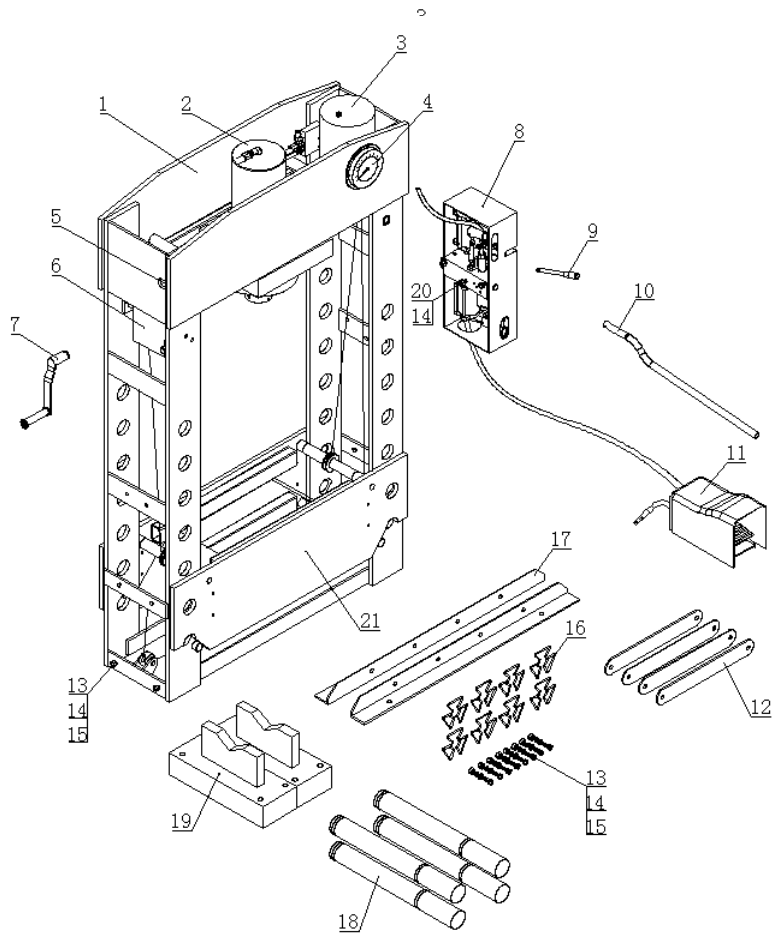

No.	Description	Qty.	Remark
1	Body Frame	1	
2	Ram Assy.	1	Assembled in the body frame
3	Oil Tanks Assy.	1	Assembled in the body frame
4	Pressure Gauge	1	Assembled in the body frame
5	Ram Moving Equipment	1	Assembled in the body frame
6	Working Bed Lifting Equipment	1	Assembled in the body frame
7	Handel	1	
8	Pump Assy.	1	
9	Handel Lever For Select Valve	1	
10	Handel Tube	1	
11	Air Foot Valve	1	Assembled in the pump assy.
12	Support	4	

13	Hex Bolt M12*30	12	8pcs in the hardware kit, 4pcs fixed on the body frame
14	Spring Washer $\phi$ 12	15	8pcs in the hardware kit, 4pcs fixed on the body frame, 3pcs fixed on the pump assy
15	Washer $\phi$ 12	12	8pcs in the hardware kit, 4pcs fixed on the body frame
16	Circlip	8	In the hardware kit
17	Base	2	
18	Pin	4	
19	Heel Block	2	
20	Hex Bolt M12*25	3	Fixed on the pump assy.
21	Working Bed	1	Assembled in the body frame

## 11. Assembling

### 11.1 Base:

Disassemble the hex bolt M12\*30 (30), washer  $\phi$  12 (27), spring washer  $\phi$  12(31), hex nut M12 (32) from part A of the press frame body. Then assemble the base to the body frame by the above parts. (refer to fig 1)

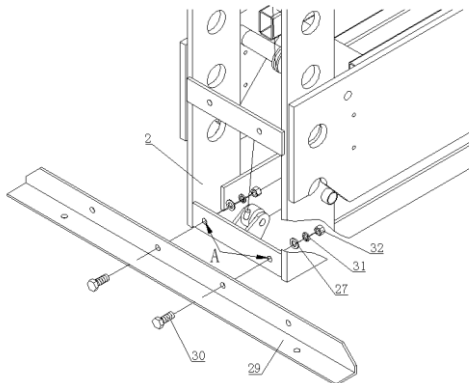

Fig. 1

11.1.2 Fix the 4pcs supports (34) to the body frame part B and C by using hex bolt M12X30 (30), washer  $\phi$  12 (27), spring washer  $\phi$  12 (31) and hex nut M12 (32). (refer to fig.2)

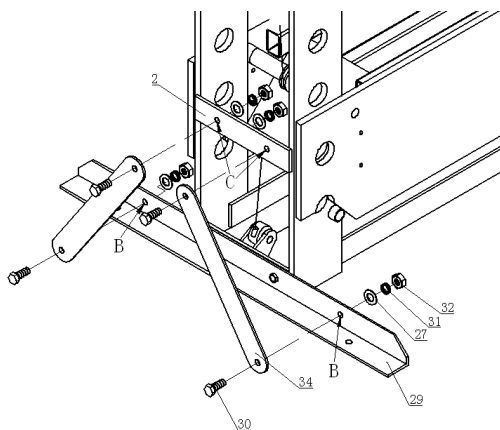

Fig. 2

## 11.2 Pump assembling

11.2.1 Fix the pump assy. (80) to the body frame by using hex bolt M12X25(33) and spring washer  $\phi$  12 (31). (refer to fig.3)

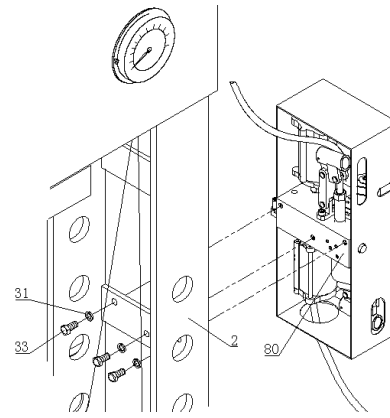

Fig. 3

11.2.2 To avoid oil spillage from the oil hose (88), a plug (93) has been added in the oil hose when packing. To remove the plug, cut the oil hose with the plug about 10mm length. (refer to fig.4)

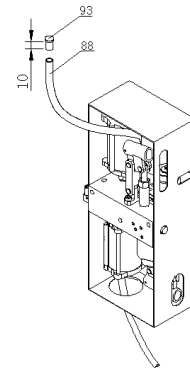

Fig. 4

11.2.3 Then connect the oil hose (88) to 1/2" connector (94) (refer to fig.5). Once the oil supply hose is connected, open the oil tank valve to allow the flow of oil and check for leaks.

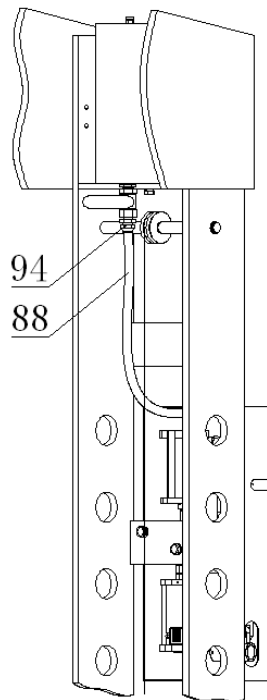

Fig. 5

11.2.4 Remove the plug of connector (97、98) and oil hose (78、79), then connect the oil hose 1 (78) and oil hose 2 (79) to connector (98) and connector (99) and tighten it. (refer to fig. 6) Note: make sure the o-rings are in the grooves of connector (97) & (98) before assembling the two oil hoses.

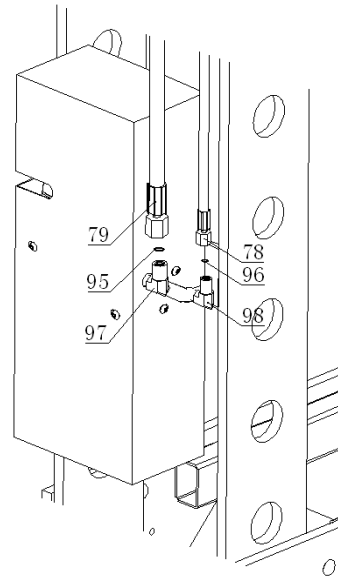

Fig. 6

11.2.5 Fix the selector lever (99) on the selector valve on the pump (80). (refer to fig. 7)

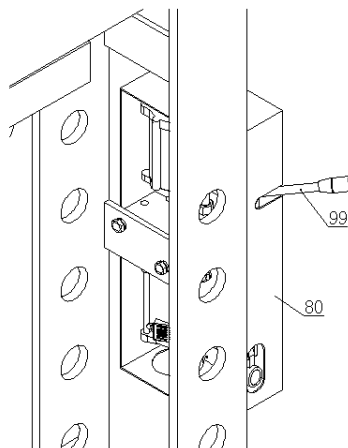
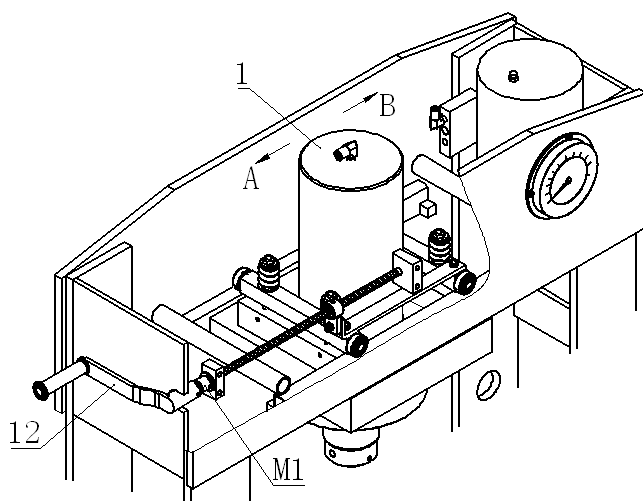

Fig. 7

## 12. Ram Moving



12.1. Insert the handle (12) to the worm connecting shaft (M1)

12.2. Turning the handle clockwise, and the ram moves left (Direction A).

12.3. Turning the handle (12) anti-clockwise, and the ram moves right (Direction B)

## 13. Bed Adjustment

13.1. Insert the handle (12) to the worm shaft (W12)

13.2. Turning the handle (12) clockwise, the working bed will lift (direction A)

13.3. Turing the handle (12) anti-clockwise, the working bed be lowered (direction B)

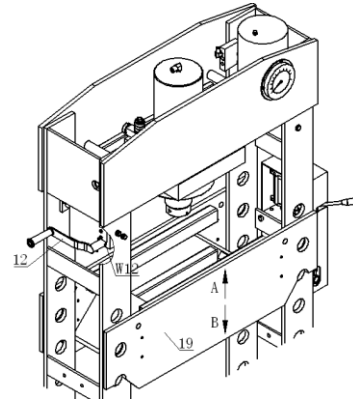

## 14. Handle Tube

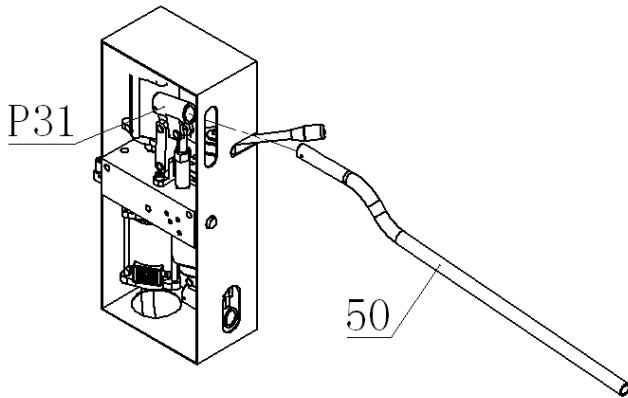

There are 2 handle sockets, one on top and one on the bottom of the pump, the upper one is for high pressure and low speed; and the lower one is for low pressure and faster speed. One handle tube is used for both pumps.

14.1. When operating the high pressure pump, insert the handle tube (50) into the handle socket (31) as shown in above fig.

14.2. When operating the low pressure pump, please insert the handle tube (50) into the socket (43). Please refer to the fig.

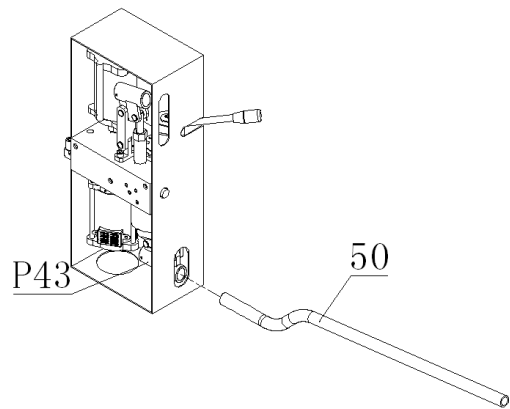

## 15. Air Purge

### 15.1. Air Purge Manually

15.1.1 Turn the handle lever of selector valve to position 2. (refer to fig. 8)

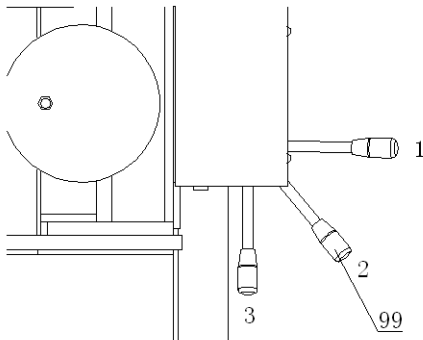

Fig 8

1	When the handle lever (99) in position 1, the piston rod is returning.
2	When the lever (99) in position 2, the piston rod is stopping moving.
3	When the handle lever (99) in position 3, the piston rod is extending.



15.1.2 Insert the handle tube (50) to the socket as process 14.2, quick pump the handle tube (50) no less than twenty circles.

15.1.3 Turn the handle lever (99) of socket valve to position 3 (refer to fig 8), and check if the ram is working properly; If the ram working properly, air purge is finished, if not, repeat the process 15.1.1~15.1.2

## 15.2. Air purge by manual high pressure valve

15.2.1 Turn the handle lever of selector valve to position 2. (refer to fig. 8)

15.2.2 Insert the handle tube (50) to the socket as process 14.1, quick pump the handle tube (50) no less than twenty circles.

15.2.3 Turn the handle lever (99) of socket valve to position 3 (refer to fig 8), and check if the ram is working properly; If the ram is working properly, air purge is finished, if not, repeat the process 15.1.1~15.1.2

## 15.3. Air purge by air

15.3.1 Connecting the air hose (P52) of the air foot valve (P54) to the compressor. (refer to fig 9)

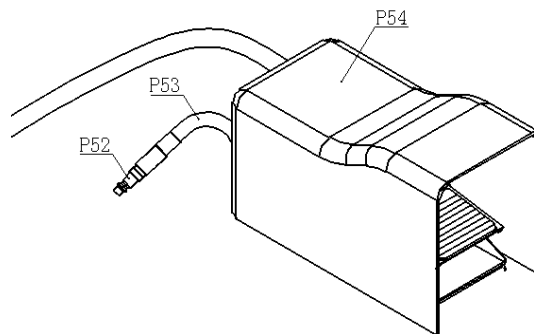

Fig. 9

15.3.2 Turn the handle lever (99) of selector valve to position 2 (fig.8), then depress the air foot valve (P54), keeping the air motor working no less than two minutes.

15.3.3 Turn the handle lever (99) to position 3 (fig 8), then depress the air foot valve (54), keeping the air motor working and check if the ram is working properly. If the ram is working properly, air purge is finished, if not, repeat the process 15.3.1~15.3.2

## 16. Piston's extension & retraction

16.1 Extending the Ram can be operated either manually or by air.

16.1.1 Operating by air:

16.1.1.1 Connecting the air hose (P52) of air foot valve to the compressor. (fig 9)

16.1.1.2 Turn the handle lever (99) of socket valve to position 3. (fig 8)

16.1.1.3 Depress the air foot valve (P54), when the piston rod is not under load, the air motor (P23) and air motor (P35) working together, then the piston rod extending quickly. When the piston rod is under load, the air motor (P35) stopping working, and only the air motor (P23) is working, then the piston rod will extend slowly.

16.1.2 Operating manually

16.1.2.1 Insert the handle tube (50) to the low pressure socket as process 14.2, then pump the handle and extend the piston rod for quicker operation of the ram.

16.1.2.2 Insert the handle tube (50) to the high pressure socket as process 14.1, then pump the handle and extend the piston rod for slower operation of the ram.

16.1.3 The operator can extend the piston rod either by air according to process 16.1.1 or manually according to process 16.1.2. **Please note that when you operate by air, NEVER operate manually according to process 16.1.2.1 (Manual Low Pressure) at the same time.**

16.2 Retracting the ram can be operated manually or by air.

16.2.1 Operated by air

16.2.1.1 Connecting the air hose (P52) of air foot valve to the compressor. (fig 9)

16.2.1.2 Turn the handle lever (99) of socket valve to position 1. (fig 8)

16.2.1.3 Depress the air foot valve (54), then the air motor (23) and air motor (P35) work together, and the piston rod returns quickly.

16.2.2 Operating manually:

16.2.2.1 Insert the handle tube (50) to the low pressure socket as process 14.2, pumping the handle returns the piston rod quickly.

16.2.2.2 Insert the handle tube (50) to the high pressure socket as process 14.1, pumping the handle returns the piston rod slowly.

16.2.3 The operator can retract the piston rod either by air according to process 16.2.1 or manually according to process 16.2.2.2. **Please note that when you operate by air, NEVER operate manually according to process 16.2.2.1 (Manual Low Pressure) at the same time.**

**16.3** To stop the movement of the piston rod: stop pumping the handle tube (50) or release the air foot valve (P54), the piston rod will stop moving. Then turn the handle lever (99) of selector valve to position 2. (fig 9)

## 17. Press Setup

17.1 Position Piston according to Section 12 so that it is centered to workpiece.

17.2 Adjust the bed (19) according to Section 13 to the appropriate height, then insert the pins (21) to the holes of body frame and lock the circlips (22).(fig 10&11)

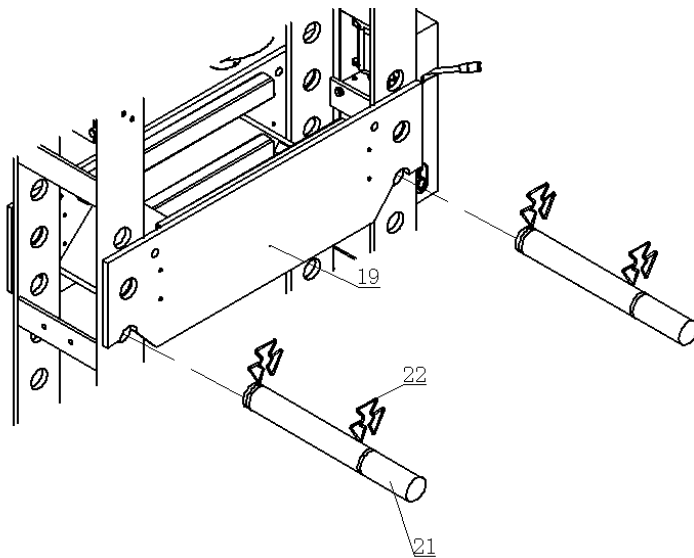

Fig 10

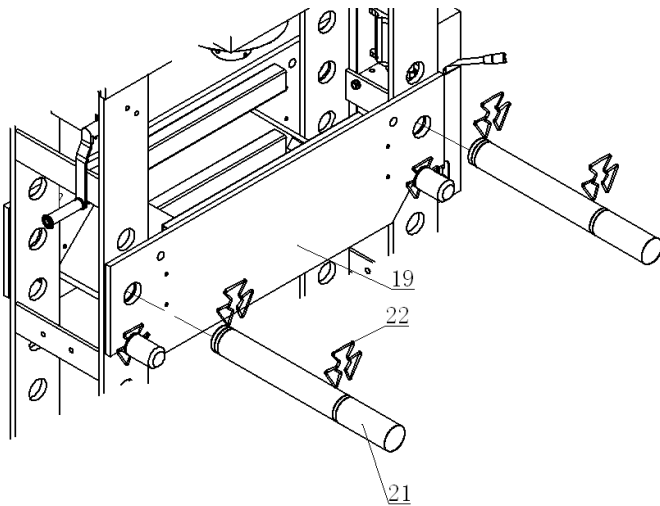

Fig 11

17.3 According to the working conditions, operator can decide which side of the heel block is up, and adjust the space of the heel blocks.

Note: to prevent the heel blocks from slipping off of the press bed, press down on the four limiting pins of the block. (fig 12)

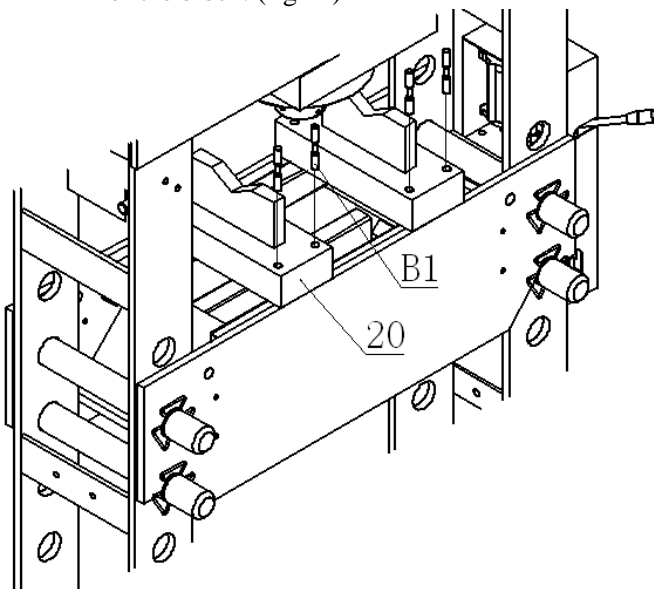

Fig 12

17.4 Put the workpiece on the heel blocks(20).

## 18. Operation

18.1 Turn the handle lever (99) of selector valve to position 3, then depress the air foot valve (P54), both air motors will operate simultaneously, and the piston rod will extend quickly. When the serrated saddle gets close to the work piece, change to manual operation.

18.2 According to handle tube usage 14.2, insert the handle tube into the high pressure socket (P31) and pump the handle tube, the piston rod extends slowly. Make sure that work piece and piston rod are aligned properly.

18.3 After adjusting the position of work piece, operator can press by air, or manually.

18.3.1 Operating by air:

Depress the air foot valve (P54), and both air motors will work simultaneously, when the serrated saddle (38) touches the work piece, the piston rod will go under pressure, and the air motor (P35) will stop

working, only the air motor (P23) will continue to work, under this condition, the piston rod extends slowly and press the work piece on the heel block. After pressing, release the air foot valve P54).

#### 18.3.2 Operating manually:

According to handle tube usage 14.2, insert handle tube into high pressure socket (P31), and pump the handle tube (50) until finished with the pressing process, then stop pumping.

#### 18.3.3 Operating both by air and manual:

Operator can press the work piece both by manual as process 18.3.2 and by air as process 18.3.1 at the same time.

18.4 Release the pressure: turn the handle lever (99) of selector valve to position 2, the pressure on the piston rod will release automatically.

18.5 Piston rod's returning: according to process 16.2

18.6 Remove the work piece.

18.7 When complete, disconnect the air hose from the compressor and clean the machine.

## 19. Maintenance

19.1 Use clean and dry cloth to clean the press surface, and grease the connecting part and moving part periodic.

19.2 When the press is not in use, fully return the piston rod and stocked in dry place.

19.3 When the press' working efficiency is reduced, purge the air in the hydraulic system according to Step 15.

19.4 Oil volume check: The operator can check if the oil volume is sufficient by pumping the handle tube to check if the piston rod can extend fully (300mm). If the oil volume is low, add hydraulic oil to the oil tank as follows: remove the screw (58) on the oil tank, add hydraulic oil then tighten the screw (58) again. After adding the oil, perform air purge according to process 15.

